

PARTS LIST:

ITEM#1	FRAME	X1
ITEM#2	PANEL	X1
ITEM#3	ASSY A	X1
ITEM#5	PLUGS	X4
ITEM#6	WOOD SCREW, STAINLESS #12X2"LONG, FLAT HD.	X2
ITEM#7	WOOD SCREW, STAINLESS #8X3"LONG, FLAT HD.	X1
ITEM#8	WOOD SCREW, STAINLESS #14X4"LONG, FLAT HD.	X3
ITEM#9	WOOD SCREW, STAINLESS #14X3" LONG, BUTTON HD.	X3



WARNING!
YOUR SAFETY DEPENDS ON ATTACHING THIS CHAIR ACCORDING TO THESE INCLUDED INSTRUCTIONS AND USING IT ACCORDING TO ITS DESIGNATED USE.

FAILURE TO DO SO COULD RESULT IN SERIOUS INJURY TO YOU OR DAMAGE TO YOUR WALL.

DESIGNATED USE:

FAILURE LOAD= 450 LB SEATED PERSON (feet resting on floor).
 MAX. REGULAR USAGE LOAD= 310 LB SEATED PERSON (feet resting on floor).
DO NOT DROP OR JUMP ON CHAIR AT ANY WEIGHT!

SURFACE MOUNT CHAIR
INSTALLATION INSTRUCTIONS: WOOD STUDDED WALLS

(Contact us for help with other types of walls.)

1. LOCATE STUD.

1a. Locate a single, uncompromized, wooden 2x4 stud to which you will attach the chair. This chair will be centered on this stud. Be sure you know exactly where any electrical is running in the vicinity so as not to puncture wires and or junction boxes. This could result in fires or electrical shock. The locations of the right and left edges of the 2x4 may be known precisely using a stud finder and or exploring with finishing nails.

2. ATTACH FRAME . FIG 2.

2a. Attach Frame (ITEM#1) to wall stud with ITEMS#9 .
 Level the top of ITEM#1 and ensure that you are screwing into the center of the stud (.75" from the edge of the stud).

FIG.2

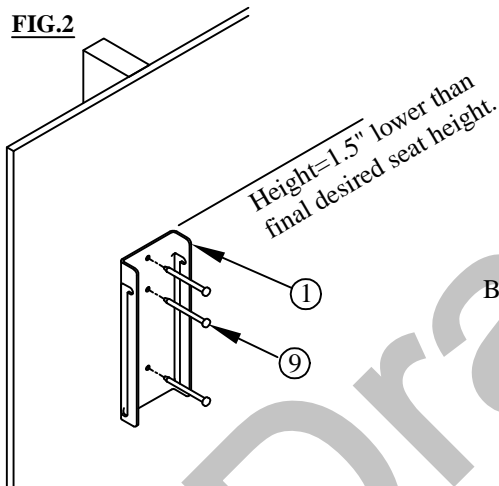

3. ATTACH PANEL . FIG.3

3a. Attach Panel (ITEM#2) to wall stud with ITEMS#7 and #8.
 Top of slot in Panel rests on top of Frame. Ensure that you are screwing into the center of the stud (.75" from the edge of the stud).

FIG.3

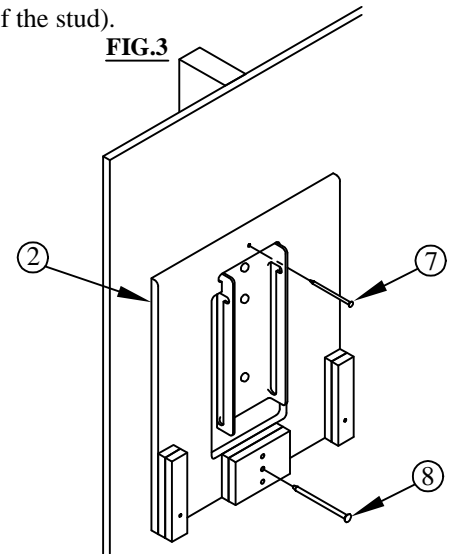

BEWARE: Do not locate chair where it will prevent the opening of a nearby door.

4. TILT IN ASSY A . FIG 4.

4a. Tilt roller pins on ASSY A (ITEM#3) into Frame (ITEM#1) and let them drop to the bottom of the slot.

FIG.4

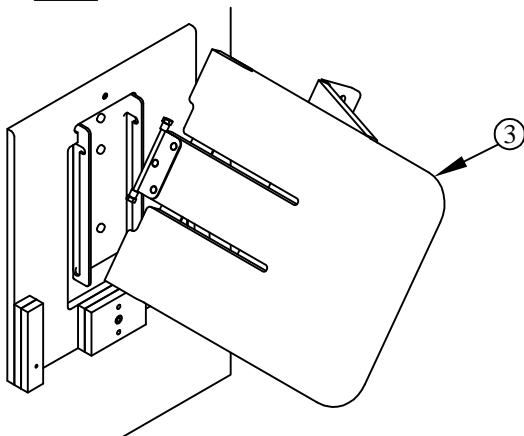

5. ATTACH ASSY A TO PANEL . FIG 5.

5a. Line up holes at bottom of ASSY A and Panel. Attach ASSY A (ITEM#3) to Panel (ITEM#2) using 2x ITEMS#8 and 2x ITEMS#6. Tap Mushroom Plugs (ITEMS#5) over screw heads. Cover Plugs with cloth or cardboard while tapping to avoid damaging them. Sand Plug Stem if fit is too tight.

FIG.5

